



CS CLEAN
SOLUTIONS

Product Information and Specifications

CLEAN-PROTECT®

Emergency Gas Release Absorber

Models: CP500SF, CS1000SF



Controlled product information. Intended use: technical reference for quotations and similar customer projects. Not intended for general distribution or for advertising purposes.

2017 - CS CLEAN SOLUTIONS AG – Property of CS CLEAN SOLUTIONS AG – All rights reserved.

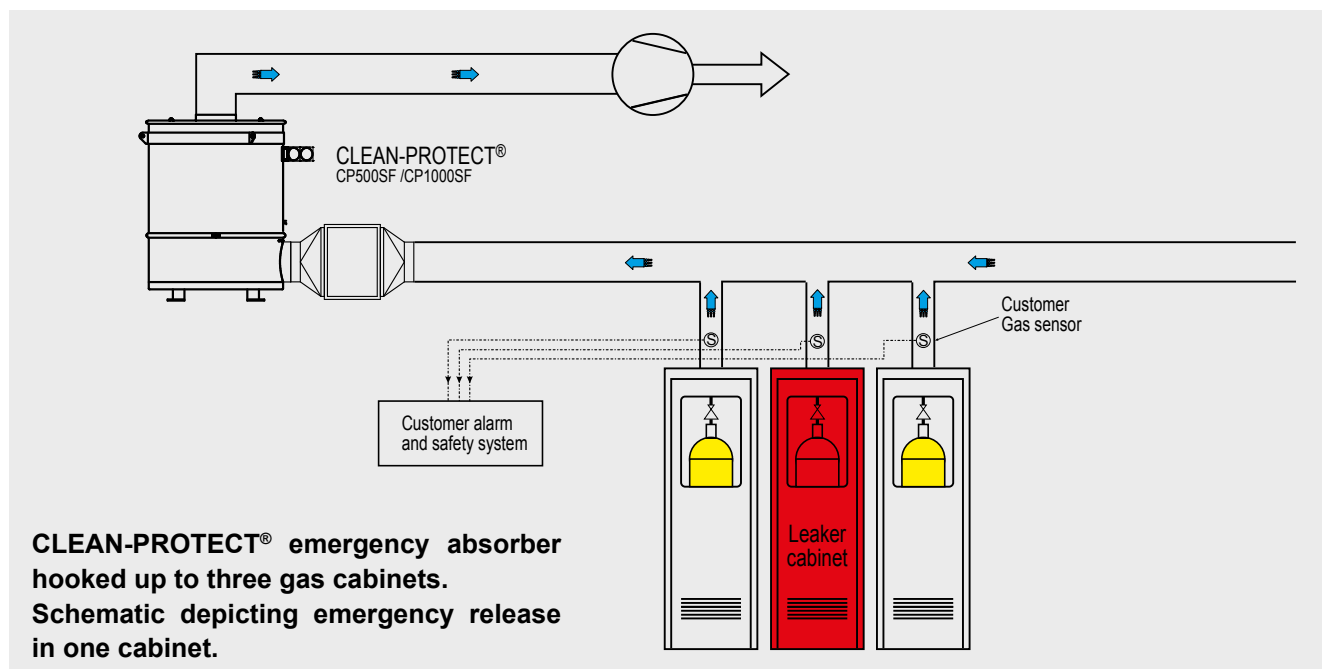

Safeguard against accidental release of hazardous gases

Hazardous process gases are commonly used in the chemical, pharmaceutical, and semiconductor industries, among others. Most usually, the gases are supplied to the process from cylinders which are housed in an air-extracted cabinet. Larger supply vessels are often stored in concrete bunkers connected to a forced ventilation duct.

Hazardous release from gas cylinders poses a very serious threat to the workforce and factory neighborhood.

The CLEAN-PROTECT® product line was specially developed to absorb toxic, corrosive, or pyrophoric gases during an emergency gas release incident.

At the heart of the CLEAN-PROTECT® system is the dry chemisorbent material, CLEANSORB®. Installed in-line, the system is constantly on stand-by. Escaping gases undergo an irreversible chemical reaction (oxidation or neutralization) within the CLEAN-PROTECT® system, where they are safely converted into non-volatile, solid by-products. Provided the system has not absorbed gas, the chemisorbent bed has a stable lifetime of up to five years between change-outs.

CP systems can also be used for selected non-emergency applications involving high airflows.

CLEAN-PROTECT® Emergency Gas Release Absorber

- High air extract flowrates, protection of multiple gas cabinets
- Scrubbing capacity for full gas cylinder
- Low pressure drop
- Permanently online, practically no maintenance
- Fully passive – no electrical connections
- Typical 5 years service life between absorber refills
- Applicable to a wide range of hazardous gases, including:
 - AsH_3 , BF_3 , Br_2 , Cl_2 , ClF_3 , COCl_2 , F_2 , HCl , HF , HBr , H_2S , H_2Se , HCN , NH_3 , N_2H_4 , PH_3 , SO_2

Worldwide Service and Support

- CS CLEAN SOLUTIONS customers can avail of a worldwide sales and service network.
- Given the important safety function assigned to the CLEAN-PROTECT® system, commissioning, maintenance and refilling is only permitted by authorized CS CLEAN SOLUTIONS service partners.

Important!

The configuration of a CLEAN-PROTECT® emergency absorber system requires careful consideration by the manufacturer of the exhaust gases to be treated and the associated installation.

Before requesting a system recommendation or quotation, please ask your authorized CS CLEAN SOLUTIONS sales and service partner to provide you with a Process Definition form so that we can recommend a model and configuration which is optimized for your process.



Available Models	Column Size
CLEAN-PROTECT® CP500SF	Approx. 500 liter
CLEAN-PROTECT® CP1000SF	Approx. 1,000 liter

Basic System Components and Configuration

<p>System Description</p>	<p>Cylindrical absorber column, constructed from 316L stainless steel. Filled with CLEANSORB granulate to safely remove hazardous gases by irreversible chemical reaction at ambient temperature. The scrubber medium is free of combustible materials such as activated carbon or organic binders.</p> <p>Suitable for installation in the air extract ducting downstream of one or several gas cabinets, allowing permanent airflow through the absorber bed. Specially designed to handle high airflows with minimal pressure drop. To be fitted with inlet dust filter accessory (refer to optional items).</p> <p>Two individual differential pressure gauges mounted on cylindrical body to monitor pressure drop across inlet dust filter and main absorber bed.</p> <p>Anchoring sockets on support legs for seismic protection.</p>
<p>Documentation</p>	<p>Operating manual in English or German language with customer-specific specifications.</p>

Available Options

Inlet Connection Options	Butt end Ø 355 mm
	Bolted flange Ø 355 mm
	Bolted flange with adapter for butt end Ø 355 mm
Inlet Connection Options	Butt end Ø 355 mm
	Bolted flange Ø 355 mm
	Bolted flange with adapter for butt end Ø 355 mm
	Filter box galvanized, Ø 355, horizontal mounting, insert on top
	Filter box galvanized, Ø 355, horizontal mounting, insert right
	Filter box stainless steel, Ø 355, vertical mounting
	Filter box stainless steel, Ø 355, horizontal mounting, insert on top
	Filter box stainless steel, bolted flange, horizontal mounting, insert top
	Filter box stainless steel, bolted flange, vertical mounting



Photo showing CLEAN-PROTECT® with inlet dust filter for vertical connection. Though specifications for this and other non-standard configurations are not provided in this document, we will be pleased to advise you regarding your individual installation requirements.

System Specifications

Series	CLEAN-PROTECT
Models	CP500SF, CP1000SF

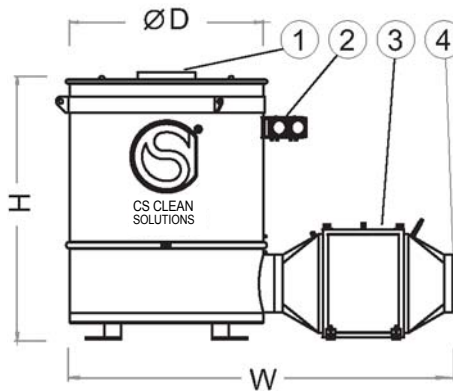

- 1 Connection for gas outlet
 ϕ 355 mm (14 in), butt end or bolted flange (according to DIN24154)
 flow for CP500SF: < 1800 m³/h (1060 foot³/minute)
 flow for CP1000SF: < 3600 m³/h (2120 foot³/minute)

- 2 Differential pressure displays
 0...500 Pa (display for pressure drop over pre-filter)
 0...2 kPa (display for pressure drop over pre-filter + absorber)

- 3 Pre-filter (particle filter)
 material of housing: stainless steel (different material on request);
 orientation: horizontal (option: vertical)
 dimensions: 1140 mm x 654 mm x 654 mm
 (44.9 in x 25.7 in x 25.7 in)
 filter type: bag filter, HS-PAK 35

- 4 Connection for gas inlet
 ϕ 355 mm (14 in), butt end or bolted flange (according to DIN24154)
 flow for CP500SF: < 1800 m³/h (1060 foot³/minute)
 flow for CP1000SF: < 3600 m³/h (2120 foot³/minute)

Model	H	W	D
CP500SF	1660 mm (65.35 in)	2440 mm (96.06 in)	1200 mm (47.24 in)
CP1000SF	2450 mm (96.45 in)	2440 mm (96.06 in)	1200 mm (47.24 in)

Weight
 with heaviest filling 1000 kg (2205 lb) for CP500SF
 1600 kg (3527 lb) for CP1000SF

Pressure build up
 at max. flow 6...11 mbar (0.09...0.16 psi) for
 CP500SF
 7...12 mbar (0.10...0.17 psi) for
 CP1000SF

Lifetime of
 absorber filling 5 years, if no contact with toxic gas
 after contact with toxic gas, the filling is to be
 exchanged to get ready for use again

On-site Conditions for System Operation

Temperature range	5...35 °C (41...95 °F); for special setups and applications a range of up to -28...+60 °C (-18...+140 °F) is possible
Humidity	80 % relative humidity (non-condensing!)
Installation site	indoors, illumination > 270 lux, mechanical ventilation or outdoors (protected from unauthorized access)
Altitude	max. 2000 m (6600 ft) above sea level
Floor space	absolutely level; according to DIN 18202

 Contact the manufacturer CS CLEAN SOLUTIONS AG for further details on outdoor installation.

Space requirement for installation and refill

The CLEAN-PROTECT safety absorber is to be refilled on site. Space is needed for a pallet jack or forklift truck as well as a platform ladder.

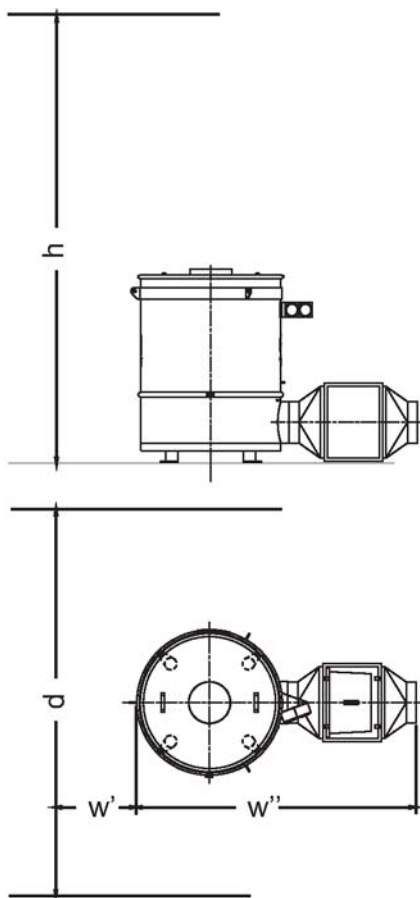

Model	h	w'	w''	d
CP500SF	3550 mm (140 in)	600 mm (24 in)	2440 mm (96 in)	3300 mm (130 in)
CP1000SF	4250 mm (168 in)	600 mm (24 in)	2440 mm (96 in)	3300 mm (130 in)



**CS CLEAN
SOLUTIONS**

CS CLEAN SOLUTIONS AG

Fraunhoferstrasse 4

85737 Ismaning, Germany

Phone: +49 (89) 96 24 00-0

Fax: +49 (89) 96 24 00-122

E-mail:

General: welcome@csclean.com

Distribution: sales@csclean.com

URL: www.csclean.com