

SERIES AP 37, 38 & 39

1/2 INCH DIAPHRAGM VALVE

Springless – manual and pneumatic (NC & NO)

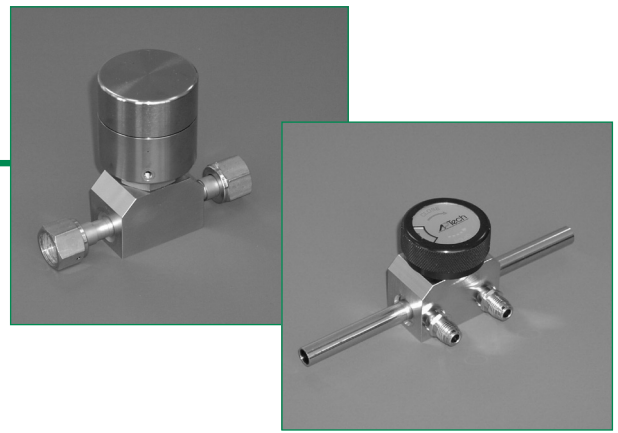

- 316L VAR SS secondary remelt construction
- Operating pressure vacuum to 250 psig (17 bar)
- Machined from bar stock
- Multi-port and monoblock available (refer to page 4)
- LOTO AP 3900
- Flow capacity 2.8 C_v
- Surface finish 15 Ra max/10 Ra avg (10, 7 & 5 Ra max options)
- Indicating switch – AP 3700 and AP 3708 option
- Installation and operating instructions available at www.aptech-online.com in the Tech Briefs section

Manual valves

	PSIG / BAR 250 / 17
AP 3800	●
– Round knob	
– Open/closed status indicating window	
AP 3900	●
– Round knob	
– Open/closed status indicating window	
– Pull, then turn to open – operational or safety feature	
– Lock out/tag out (LOTO) – integral standard feature	

Pneumatic valve, normally closed (NC)

	PSIG / BAR 250 / 17
AP 3700	●
– Switch option for remote monitoring	

Pneumatic valve, normally open (NO)

	PSIG / BAR 250 / 17
AP 3708	●
– Switch option for remote monitoring	

All specifications subject to change without notice.

HIGH PURITY ~ HIGH VALUE

Operating Parameters — all valves

Inlet pressure	vacuum to 250 psig (17 bar)
Outlet pressure	vacuum to inlet pressure
Proof pressure	150% of operating pressure
Burst pressure	300% of operating pressure

Other Parameters — all valves

Inlet /outlet connectors	3/8, 1/2 or 3/4 inch face seal or tube weld
Flow coefficient (Cv)	2.8, Xr = 1.0
Internal volume	0.76 in ³ (12.52 cm ³)
Operating temperature	-40° to +160°F (-40° to +71°C)*
Surface finish	15 µin. Ra max /10 µin. Ra avg. (0.4/0.25 µm) standard; 10 µin (0.25 µm); 7 µin (0.18 µm); and 5 µin (0.13 µm) Ra max optional Optional surface finishes meet or exceed 5 µin Ra average
Inboard leakage	2 x 10 ⁻¹⁰ sccs
Outboard leakage	2 x 10 ⁻⁹ sccs He
Leakage across seat	1 x 10 ⁻⁹ sccs He

Operating Parameters — pneumatic valves

Status	AP 3700 AP 3708	normally closed (NC) normally open (NO)
Actuation port		M5, side port
Actuation pressure		80 to 100 psig (5.5 to 7 bar)

Materials — wetted parts, all valves

Body	SS 316L secondary remelt
Finish	electropolished and passivated
Diaphragm	stainless steel 316L (Ni-Cr-Mo alloy optional)
Seat	PCTFE (Polyimide optional)

*VS option 14° to 194°F (-10° to + 90°C).

All specifications subject to change without notice.

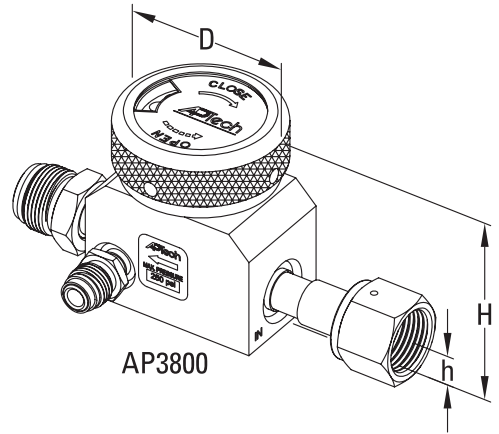
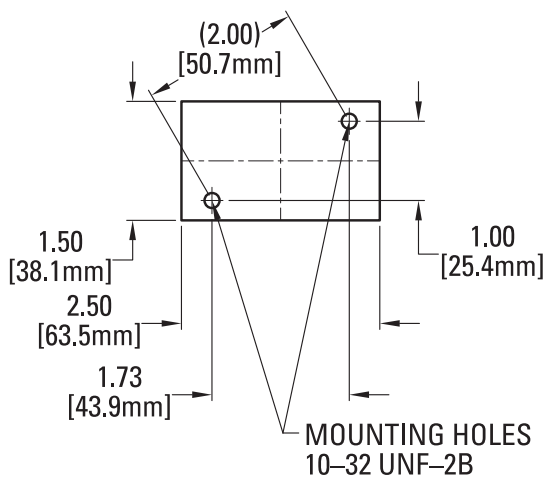
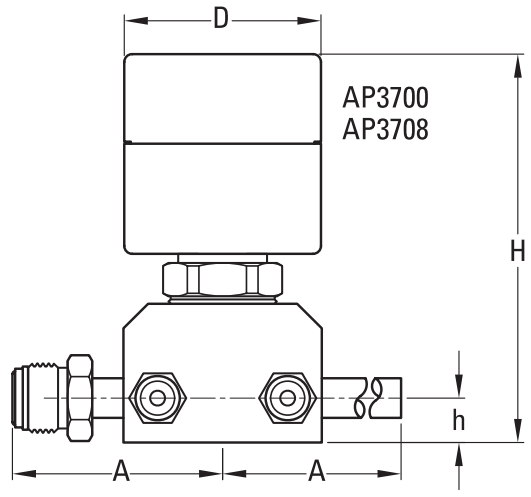
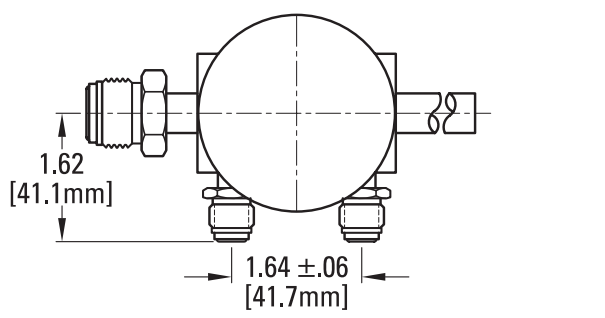

AP3800

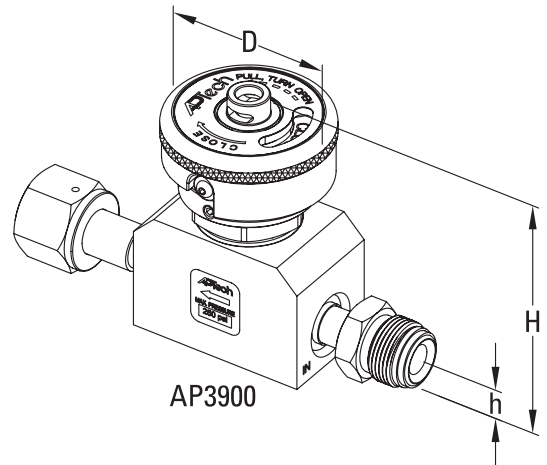

AP3900

- Metric dimensions are for reference only.
- Height of the valve (H) is an approximate value.
- All specifications subject to change without notice.
- AP3800 valve is shown in open position, AP3900 valve is shown in closed position.
- Fitting dimensions do not apply to monoblock configurations

VALVE	D		H		h	
	inch	mm	inch	mm	inch	mm
AP3700	ø2.48	63.0	5.0	127	.56	14.2
AP3708	ø2.48	63.0	4.4	112	.56	14.2
AP3800	ø2.25	57.2	2.85	72	.56	14.2
AP3900	ø2.25	57.2	3.64	92	.56	14.2

CONNECTION	A	
	inch [±.02]	mm
FV8, MV8	2.65	67.3
TW6, TW8, TW12	4.25	108
FV12, MV12	3.20	81.3

ULTRACLEAN TECHNOLOGY BACKED BY SERVICE AND SUPPORT

MONOBLOCK CONFIGURATIONS

AP3710, AP3810 & AP3910 Single Horizontal Tee

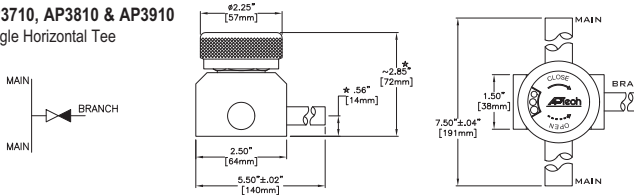

AP3810 shown

* VARIES FOR DIFFERENT SIZES OF MAIN

AP3740, AP3840 & AP3940 Dual Vertical Tee

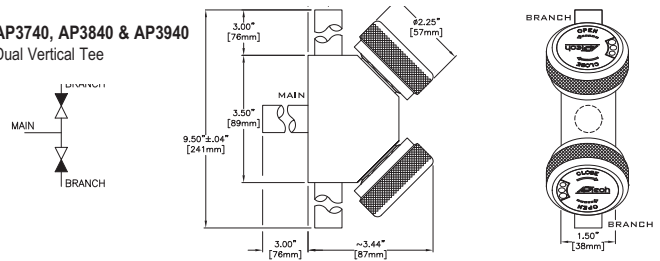

AP3840 shown

AP3720, AP3820 & AP3920 Single Vertical Tee

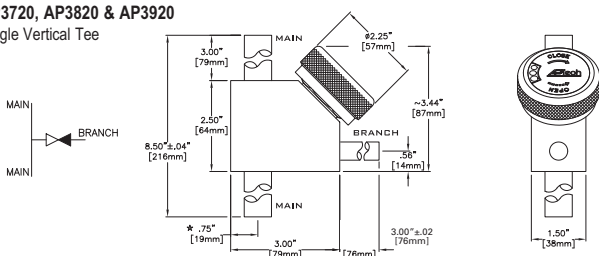

AP3820 shown

* VARIES FOR DIFFERENT SIZES OF MAIN

AP3750, AP3850 & AP3950 Dual Horizontal Tee

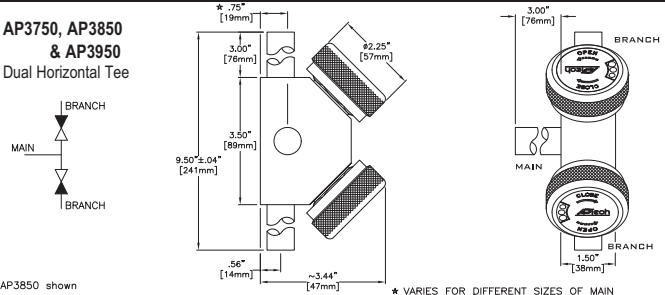

AP3850 shown

* VARIES FOR DIFFERENT SIZES OF MAIN

AP3730, AP3830 & AP3930 Dual Horizontal Cross

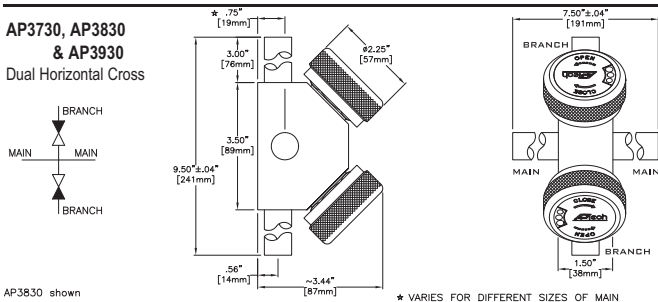

AP3830 shown

* VARIES FOR DIFFERENT SIZES OF MAIN

- Standard monoblock configurations
- Custom models available upon request
- Monoblock fitting dimensions apply to tube stub only, consult factory for face seal dimensions

CAUTION: Product selection is the sole responsibility of the user, regardless of any recommendations or suggestions made by the factory. The user shall make selections based upon their own analysis and testing with regard to function, material compatibility and product ratings. Proper installation, operation and maintenance are also required to assure safe, trouble free performance.

ORDERING INFORMATION

Sample Order Number

AP 3700SM TW8 TW8 0B C

AP 37 | Series

AP 37 = Air actuated
AP 38 = Manual
AP 39 = Manual, LOTO

Monoblock
Option

00 | Choose One

Status
(2 port only)

s | Material

S = Stainless steel (SS)

M | Surface
Finish
Options

M = 10 µin. Ra max
V = 7 µin. Ra max
X = 5 µin. Ra max

TW8 TW8 | Connections
Inlet / Outlet
(main / branch)

TW6 = 3/8 inch tube stub weld
FV8 = 1/2 inch face seal female
MV8 = 1/2 inch face seal male
TW8 = 1/2 inch tube stub weld
FV12 = 3/4 inch face seal female
MV12 = 3/4 inch face seal male
TW12 = 3/4 inch tube stub weld
TW16* = 1 inch tube stub weld
TW24* = 1 1/2 inch tube stub weld

NOTE: Further connections are available.
Please consult factory.

0B | Purge Port
Inlet / Outlet
(main / branch)

M = Inlet purge port**
B = Outlet purge port
0 = No purge port

c | Options

VS = Polyimide Seat
ISC = Indicator Switch, NC (3700 & 3708 only)***
ISO = Indicator Switch, NO (3700 & 3708 only)***
C = Capped Purge Port
HD = Diaphragm Ni-Cr-Mo alloy
SC = Short bonnet

AP Tech has product options and variations which are not documented in data sheets. If you have a model number that is not defined by the ordering information, please consult the factory or your local representative.

*TW16 and TW24 available on main only with monoblock option. **Not available in monoblock. ***Refer to operating manual for further switch information.